



Technical specification

Recycler WR 2500 S



Technical specification

	Recycler WR 2500 S Working width 8'	Recycler WR 2500 S Working width 10'
Working width max.	8' 2,438 mm	10' 3,048 mm
Working depth *1	0 – 20" 0 – 500 mm	0 – 20" 0 – 500 mm
Milling and mixing rotor		
Tool spacing	11/4" 30 mm	11/2" 37 mm
Number of tools	224	224
Drum diameter with tools	4' 10" 1,480 mm	4' 10" 1,480 mm
Engine		
Manufacturer	Mercedes-Benz	Mercedes-Benz
Type	OM 444 LA	OM 444 LA
Cooling	Water	Water
Number of cylinders	12	12
Output	500 kW/670 HP/680 PS	500 kW/670 HP/680 PS
Engine speed	2,100 min ⁻¹	2,100 min ⁻¹
Displacement	1,338 in ³ 21,930 cm ³	1,338 in ³ 21,930 cm ³
Fuel consumption, full load	31.7 gal/h 120 l/h	31.7 gal/h 120 l/h
Fuel consumption, 2/3 load	21.1 gal/h 80 l/h	21.1 gal/h 80 l/h
Speeds/Gradeability		
1 st advance speed	0 – 50 ft/min 0 – 15 m/min	0 – 50 ft/min 0 – 15 m/min
2 nd advance speed	0 – 131 ft/min 0 – 40 m/min	0 – 131 ft/min 0 – 40 m/min
3 rd advance speed	0 – 262 ft/min 0 – 80 m/min	0 – 262 ft/min 0 – 80 m/min
4 th advance speed	0 – 656 ft/min 0 – 200 m/min	0 – 656 ft/min 0 – 200 m/min
Theoretical gradeability, max.	57 %	57 %
Transversal inclination, max.	8 °	8 °
Ground clearance	15" 370 mm	15" 370 mm
Weights*2		
Front axle load, full tanks	38,581 lbs 17,500 daN (kg)	40,345 lbs 18,300 daN (kg)
Rear axle load, full tanks	34,172 lbs 15,500 daN (kg)	35,274 lbs 16,000 daN (kg)
Own weight	69,446 lbs 31,500 daN (kg)	72,312 lbs 32,800 daN (kg)
Operating weight, CE *3	70,548 lbs 32,000 daN (kg)	73,414 lbs 33,300 daN (kg)
Operating weight, full tanks	72,753 lbs 33,000 daN (kg)	75,619 lbs 34,300 daN (kg)
Tyres		
Type of tyres	Diagonal	Diagonal
Tyre size, front/rear	28 L 26	28 L 26
Tank capacities		
Fuel tank	396 gal 1,500 l	396 gal 1,500 l
Hydraulic fluid tank	71 gal 270 l	71 gal 270 l
Water tank	132 gal 500 l	132 gal 500 l
Electrical system	24 V	24 V
Shipping dimensions		
Dimensions of machine (L x W x H)	27'11" x 10'6" x 10'6" 8,500 x 3,200 x 3,200 mm	27'11" x 10'6" x 10'6" 8,500 x 3,800 x 3,200 mm

*1 = The maximum working depth may deviate from the value indicated, due to tolerances and wear.

*2 = All weights refer to basic machine including operator's cabin, but without any other additional equipment.

*3 = Weight of machine with half-full water tank, half-full fuel tank, driver (165.4 lbs/75 kg) and tools.

Dimensions in American standard and mm

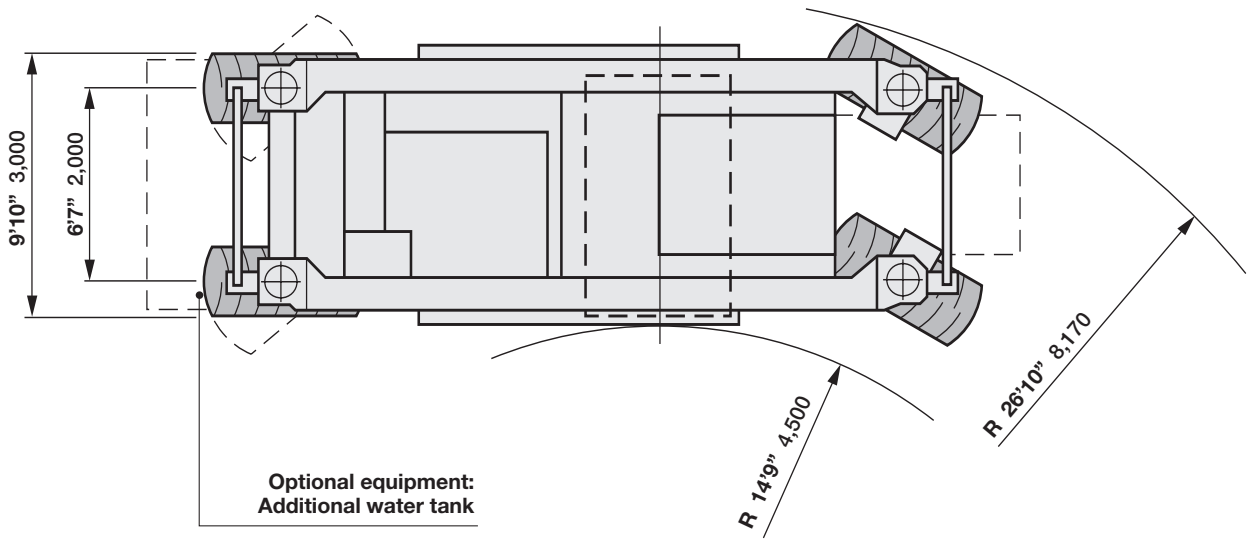
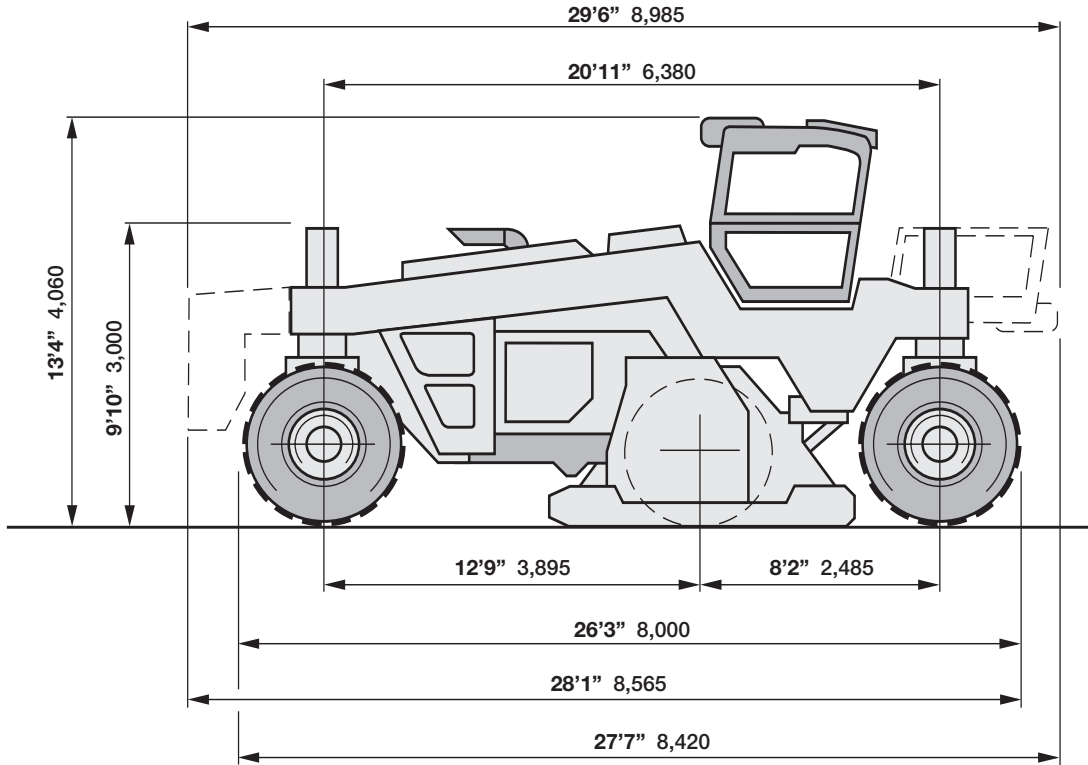

Width of machine with optional working width 10' (3,048 mm): 12'2" (3,700 mm)

Basic design

Recycler and stabilizer with mechanically driven milling and mixing rotor and two working directions.

Chassis

Rigid welded construction with mounts for the individual units and attachments.

The water tank is integrated into the chassis.

All components are easily accessible for maintenance and servicing.

Soundproofing

Noise levels are reduced by the standard soundproofing which also protects both the operating personnel and the environment against any nuisance due to noise.

Operator's platform

The operator's platform with seat and control console is located at the centre of the machine. The steering wheel can be tilted and adjusted in height.

The ergonomic sitting position, low machine design and clear overview allow an easy operation of the machine.

The modern control and operating elements are located within easy reach and within the operator's field of vision.

The entire platform can be shifted to either side.

In addition, the seat console (driver's seat and control consoles) can be infinitely turned by 90° to ensure an optimum overview of the construction site at all times.

Operator's cabin

The recycler can be equipped with a fully enclosed operator's cabin as an equipment option. It provides optimum protection against inclement weather and can, upon request, be supplied with an air-conditioning system.

Heated front and rear screens are a standard feature.

The cabin is equipped with a lockable stowing compartment and an additional seat.

The entire cabin can be shifted to the right beyond the edge of the machine.

Machine control CGC (Cockpit Graphic Centre)

All machine functions are controlled or regulated by means of microcontrollers. All control modules are accommodated in an easily accessible control cabinet.

The operator has immediate access to data, such as operating hours, oil pressure, engine temperature, engine speed, hydraulic fluid temperature, filling level of the diesel tank, wheel position or travel speed, via the display of the CGC at the operator's platform.

If necessary, the integrated Wirtgen information and diagnosis system generates visual and audible alarms. The data and messages, e.g. contamination of hydraulic fluid filter or air filter, are indicated on the display of the CGC at the operator's platform.

All inputs for the calibration of the recycler are made via the CGC. The job data can be indicated on the CGC display or printed by means of an optional printer.

Power unit

The machine is driven by a modern, powerful V 12 engine.

The engine complies with the stringent requirements of the exhaust emission standards stipulated by the US Environmental Protection Agency (EPA, Tier II) and the EU (Stage II). It is equipped with a fully electronic engine management system and offers maximum torque stability even at extreme engine loads, thus preventing breaks in operation.

An extremely large cooler surface effectively cools the engine and other components, thus allowing the safe operation of the machine even at high outside temperatures.

The cooling system is additionally equipped with a fan controller. The fan speed is reduced at low ambient temperatures or low loads, thus reducing the noise emission levels and fuel consumption. All servicing work on the engine can be carried out from the ground.

Power control

The machine is equipped with an automatic power control which governs the advance speed in accordance with the engine load. The power control can be deactivated to allow manual adjustment of the advance speed.

Milling and mixing rotor drive

The milling and mixing rotor is driven mechanically by the diesel engine via a mechanical clutch and power belts acting on the drum gearbox. The power belts are tensioned automatically by means of a hydraulic cylinder. Four possible speeds of the milling and mixing rotor ensure optimum working results.

Milling and mixing rotor

The milling and mixing rotor operates in up-milling or down-milling direction, depending upon the direction of travel. Quick-change toolholders type HT11, which accommodate the point-attack cutting tools, are welded onto the drum body. Special, individually replaceable edge segments are additionally mounted onto the outer edges of the drum. Hydraulically adjustable scraper blades in front of and behind the drum ensure good mixing results. The pre-set angle of the crusher bar and/or the scraper blade is indicated on the CGC display.

Cutting tool replacement

The hydraulically swivelling scraper blade provides good access to the milling and mixing rotor for the replacement of tools. The quick-change toolholder system minimizes the time required for maintenance work.

Turning of the milling and mixing rotor for the replacement of tools is facilitated considerably by means of a hydraulically operated drum turning device (equipment option).

Milling depth control

The machine is set in transport or working position by means of the four lifting columns. The working depth is adjusted by lowering the milling and mixing rotor. The current working depth is indicated on the CGC display at the operator's platform.

The machine operator can pre-select as to whether the front or the rear lifting columns act as a full floating axle or leveling axle.

Drive unit

The wheels of the recycler WR 2500 S are connected to the chassis by means of hydraulically height-adjustable cylindrical columns. The standard heavy-duty tyres are equipped with side guards and reinforced studs.

Travel drive

Each wheel is driven by its own hydraulic motor. Each hydraulic motor is fed by a hydraulic variable displacement pump. The four travel speeds can be infinitely varied from zero to maximum working speed in milling and travel gear. A permanent differential lock ensures uniform traction. The advance speed is regulated at the operator's platform.

Brake system

Braking is achieved by the self-locking hydrostatic transmission. In addition, the wheels can be locked from the operator's platform by means of a multiple-disk parking brake.

Steering

The WR 2500 S has a finger-light hydraulic four-wheel steering system which can be adapted to the selected working direction, i.e. either the front or the rear wheels act as steering axle. By means of a selector switch, the operator can choose between three different steering modes ("normal", "crab steering" and "coordinated steering").

In normal mode, the front wheels are steered via the steering wheel, while sensors automatically maintain the rear wheels in straight-ahead position.

They can, however, also be operated independently of the front wheels via a joystick.

Hydraulic system

Independent hydraulic systems for travel drive, setting functions and cooling system. The hydraulic pumps are driven by the diesel engine via a splitter gearbox.

Electrical system

24 V electrical system with starter, three-phase alternator and two 12 V batteries, as well as complete working lights, including two freely positionable lamps with magnetic pedestals.

Cold recycling system: Injection system for water or binding agents with one injection bar

The injection system consists of a microprocessor-controlled metering unit, an eccentric pump and an injection bar with 16 nozzles and feeding device.

The pump delivers the liquid agent (e.g. water or bitumen emulsion) from a tanker truck to the injection bar.

The eccentric worm pump has a maximum delivery rate of 211 gal/min (800 l/min). A flow meter monitors the delivered quantities and transfers the data to the microprocessor control, which in turn regulates the addition of binding agent or water in accordance with the pre-selected parameters.

An automatic shut-off device enables the individual nozzles to be opened and closed by means of hydraulic cylinders, thus allowing the addition of binding agents to be effectively

adapted to the working width. The nozzles are cleaned automatically.

Second pump

A second pump can be integrated to facilitate the simultaneous addition of water and bitumen emulsion into the mixing chamber via one injection bar.

The addition is also governed by means of a microprocessor-controlled metering unit.

Second injection bar

An additional injection bar can be integrated for the purpose of adding a water-cement slurry from a preceding slurry mixer with integrated pump.

Injection system with second pump and second injection bar

This specification uses separate pumps to feed two different agents into the mixing chamber.

Alternatively, one pump can deliver water or bitumen emulsion, while the second injection bar is connected to a preceding slurry mixer.

Injection system for foamed bitumen

The injection system for foamed bitumen comprises a pump and an injection bar for foamed bitumen.

Foaming takes place in special expansion chambers in the injection bar.

The hot bitumen is delivered by an electrically heated gear pump and subsequently filtered.

A flow meter registers the delivered quantity of bitumen.

The addition of water and air, which are necessary for the foaming process, is governed in accordance with the bitumen quantity.

All hot-bitumen hoses in the machine are insulated and heated. The temperature is continuously measured and maintained at the pre-set value by means of a control system.

The water for the foaming process is taken from the integrated water tank of the machine.

The system is equipped with a test nozzle to check the quality of the foam.

A second injection system is provided for the addition of water to achieve the optimum moisture content of the mixture. It consists of an eccentric pump and an injection bar for water.

The water is delivered from a preceding water tanker. Alternatively, a cement-water slurry can be injected from a preceding slurry mixer.

Filling

Water and diesel fuel are filled via large filling ports.

Safety during transport

The machine can be securely lashed onto a low-bed trailer or loaded by crane with the aid of lashing lugs.

Equipment	Recycler WR 2500 S
Frame/Operator's platform	
Driver's seat with control consoles, can be infinitely turned by 90°	○
Operator's cabin	○
Heating system	○
Air-conditioning system	●
Special painting	●
Machine control and levelling system	
Machine control by means of microcontrollers	○
CGC (Cockpit Graphic Centre)	○
Printer for job data	●
Ultrasonic sensor for height adjustment	●
Slope control sensor for slope adjustment	●
Milling drum assembly	
Quick-change toolholder system HT11 with 0,8" (20 mm) shaft diameter	○
Quick-change toolholder system HT11 with 0,9" (22 mm) shaft diameter	●
Equipment for working width 10' (3,048 mm) (ex works only)	●
Crusher bar	●
Pneumatic knock-out tool	●
Hydraulic drum turning device (for cutting tool replacement)	●
Cold recycling system	
Injection system with 1 pump and 1 injection bar	●
Injection system with 1 pump and 2 injection bars	●
Injection system with 2 pumps and 1 injection bar	●
Injection system with 2 pumps and 2 injection bars	●
Injection system for foamed bitumen and water (i.e. 2 pumps and 2 injection bars)	●
Injection bar and accessories (without pump, for use with WM 1000)	●
Hot-bitumen hose for connection to bitumen tanker, various lengths	●
Additional water tank for the production of foamed bitumen, 422 gal (1,600 l)	●
Additional metering unit for 475 gal/min (1,800 l/min) water	●
Miscellaneous	
Soundproofing	○
Cyclonic air filter	○
Working lights (detachable)	○
Warning lights	○
Horn, reversing horn and exterior rear view mirrors	○
Towing device	○
4-wheel steering	○
Loading and lashing lugs	○
Comprehensive tool kit	○
CE label	○
Safety certificate by the Employer's Liability Insurance Association	○
Comprehensive safety package with emergency stop buttons	○
Compressed air system	○
High-pressure water wash down	●
Operation of the cold recycler with organic hydraulic fluid	●

○ Standard ● Option



WIRTGEN AMERICA

Wirtgen America Inc.
6030 Dana Way · Nashville, TN 37013, USA
Phone: (615) 501-0600 · Fax: (615) 501-0691
Internet: www.wirtgenamerica.com